

ECOLAB®

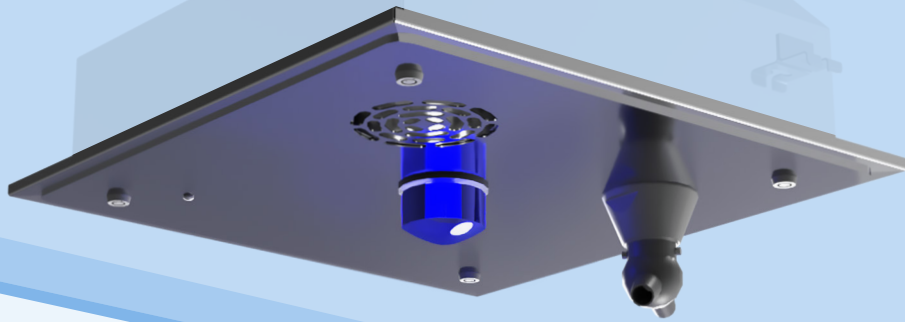

Bioquell Qlear™

The smart, cost-effective
solution for integrated
& automated room
bio-decontamination

GLOBAL EXPERTS IN
CONTAMINATION CONTROL

Faster install & faster cycles* with no cycle setup time

Integrated & automated hydrogen peroxide vapour bio-decontamination for critical areas in your facility.

The Bioquell Qlear™ modular integrated system offers a groundbreaking design for automated bio-decontamination in critical areas providing a validated 6-log sporicidal kill at the touch of a button, and without the need for complex and costly pipework.

The unique design of Bioquell Qlear generates hydrogen peroxide vapour directly within each room via ceiling-mounted units, which fit within a standard ceiling tile. These units are linked to a central control panel and liquid station, removing the need to distribute vapour through the building via pipework or ventilation ducting which can result in issues when trying to validate the bio-decontamination process.

It supports single or multi-zone bio-decontamination while integrating seamlessly with building management systems (BMS) to ensure safe operation.

Advantages of Bioquell Qlear:

- Reduced installation time and cost*
- Shorter cycle times*
- Optimised validation process
- Elimination of equipment setup, disassembly and storage needs
- Help streamline facility operations while maximising uptime and throughput



Traditional integrated bio-decontamination systems with centralised vapour generation requiring complex pipework

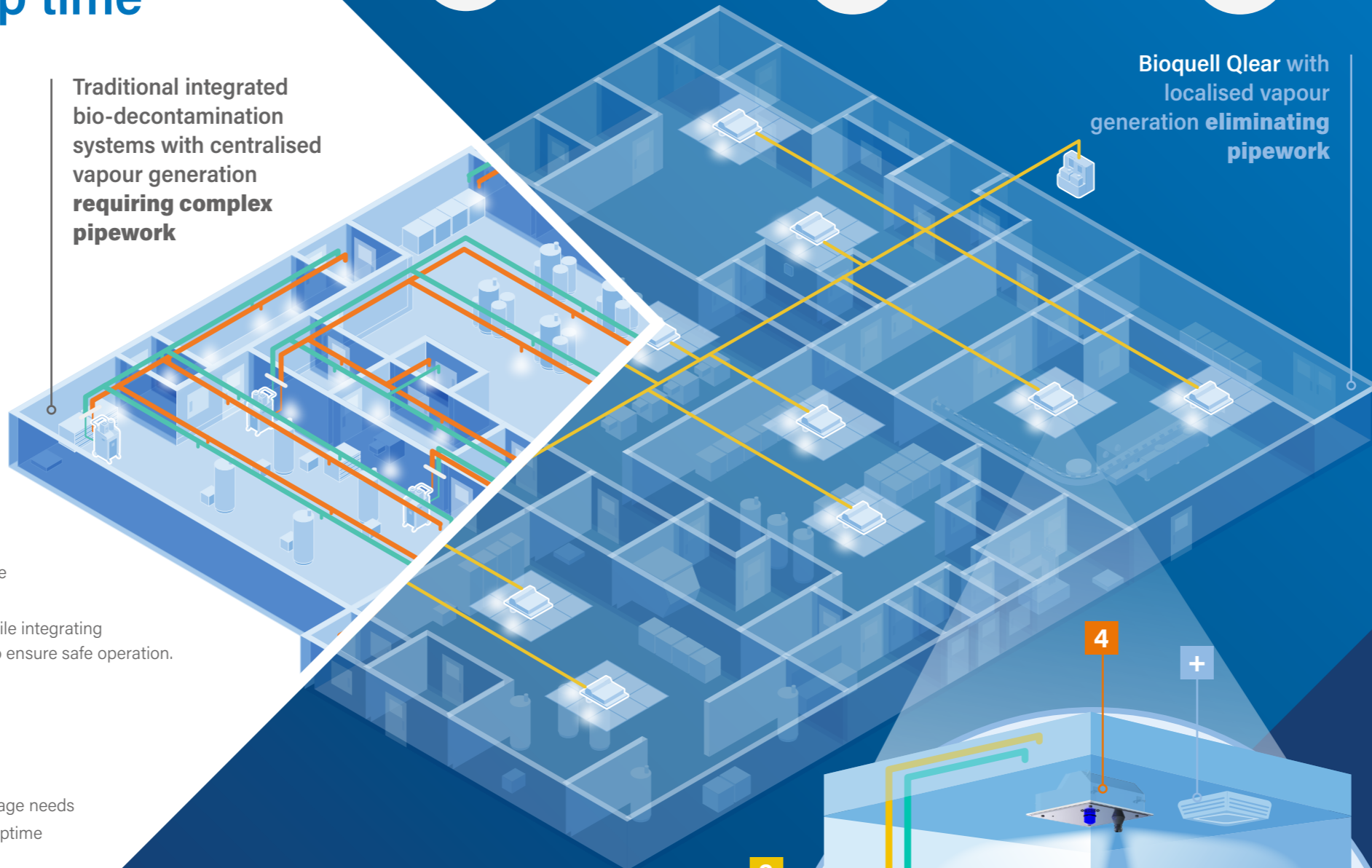

Rapid installation with minimal disruption to your facility



Easy to use and fully automated bio-decontamination cycles at the touch of a button



Facilitates bio-decontamination of individual rooms or complete zones, as required



Bioquell Qlear with localised vapour generation eliminating pipework

Benefits of Bioquell Qlear™

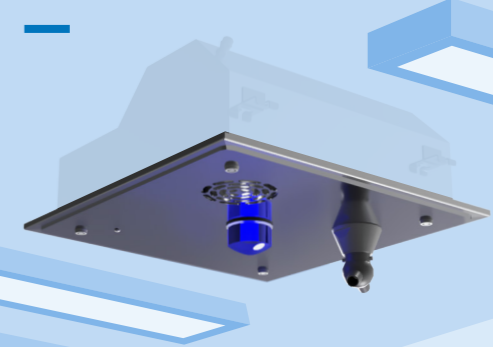

Quick installation

Due to no pipework being needed

Optimised cycle times

Due to high injection rates and excellent vapour distribution

Bioquell Qlear offers:

- Bio-decontamination cycles in a single room or multiple zones
- Repeatable bio-decontamination cycles delivering a validated 6-log sporicidal kill on all exposed surfaces
- Reduced downtime and human error by eliminating mobile equipment setup
- Faster and lower cost install due to elimination of vapour distribution pipework*
- Resource efficiency with a fully integrated 'one touch start'
- No need to dehumidify the room prior to the cycle, or for post-cycle wipe downs or additional cleaning, saving time
- RFID tagged hydrogen peroxide bottles for traceability and quality control
- Optional 21 CFR Part 11 audit trail compliance package
- Digital cycle reports to support GMP compliance

Components

- The hydrogen peroxide liquid station** is typically located in a technical area outside of the target rooms.
 - The control panel** starts cycles, communicates with the BMS/HVAC system, and manages all components including the liquid station, vaporisers, and environmental monitoring units. Extra HMI panels can be placed near target rooms for starting and monitoring the process.
 - Flexible tubing** transports liquid hydrogen peroxide from the liquid station to the vaporiser units. Communication cables connect the control panel and vaporiser units.
 - Vaporiser units** generate the hydrogen peroxide vapour which is then distributed around the room through a rotating nozzle.
 - Environmental monitoring unit** for continuous environmental feedback during the bio-decontamination process.
 - The safety panel** is used by the operator to confirm evacuation of the area as a final safety check, and has an emergency stop button.
- + Optional aeration units:** Bioquell ceiling/wall-mounted units rapidly break down the hydrogen peroxide vapour after bio-decontamination.

*Compared to alternative integrated bio-decontamination systems

Bioquell™ Hydrogen Peroxide Vapour



Bioquell's proprietary bio-decontamination technology utilises a 35% hydrogen peroxide aqueous solution which is vaporised to kill microorganisms. Whether it's for bio-decontaminating equipment or rooms, a single cycle using Bioquell Hydrogen Peroxide Vapour provides a 6-log sporicidal kill on exposed surfaces, which is validated with *Geobacillus stearothermophilus* biological indicators.

Bioquell HPV-AQ 35% hydrogen peroxide holds a European Union authorisation under the Biocidal Products Regulation (BPR, Regulation (EU) 528/2012).

Bio-decontamination products & services

- ▾ Mobile room bio-decontamination options
- ▾ Fixed room bio-decontamination systems
- ▾ Integrated bio-decontamination solutions for pass-through chambers and other small enclosures
- ▾ Rapid Bio Decontamination Service (RBDS) for rooms and facilities of any size
- ▾ Isolators with integrated bio-decontamination



For expert implementation of automated bio-decontamination measures in your facility contact your **Ecolab Account Manager**

For regional office details, please visit **bioquell.com**

USE BIOQUELL PRODUCTS SAFELY. ALWAYS READ THE LABEL AND PRODUCT INFORMATION BEFORE USE.

ECOLAB LTD

52 Royce Ct
Andover
SP10 3TS, UK
www.bioquell.com

EUROPE HEADQUARTERS

Ecolab Europe GmbH
Hofwiesenstrasse 349
CH-8050 Zürich, Switzerland
www.ecolab.com/lifesciences

